

# ASSEMBLY INSTRUCTIONS

## Kit Contents:-

1. Allen-Bolts-13Pc.

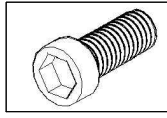

25 X 8mm

2. Washer-13Pc.

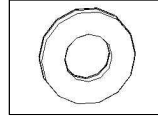

8mm

3. Allen-Key-1Pc.

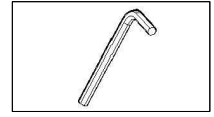

6mm

## Instructions:-

1. Put the Plasma Cabinet upside down on a protective surface with legs & stretcher.
2. Match the holes on the table leg with fastner on the bottom of the Cabinet & Secure using Allen-bolts & washers with Allen-Key provided. Similarly attach the other leg.
3. Match the holes on the Stretcher with fastner on the bottom of the Cabinet & fastner on the Cabinet leg & Secure using Allen-bolts & washers with Allen-Key provided. Similarly attach the other stretcher.
4. Turn the Cabinet upright and Now Plasma Cabinet is ready to use.

1.

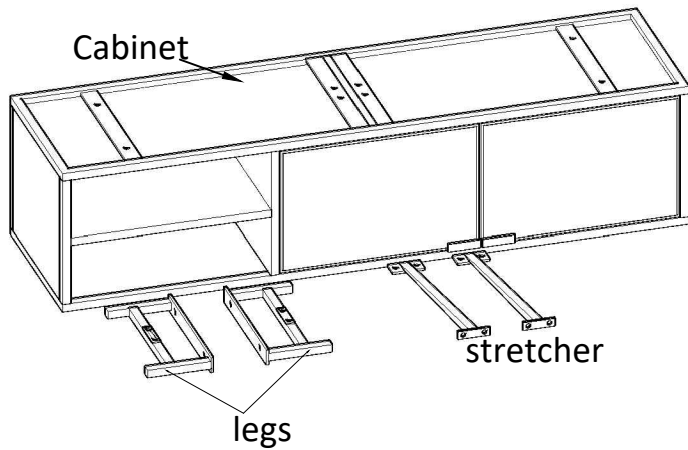

2.

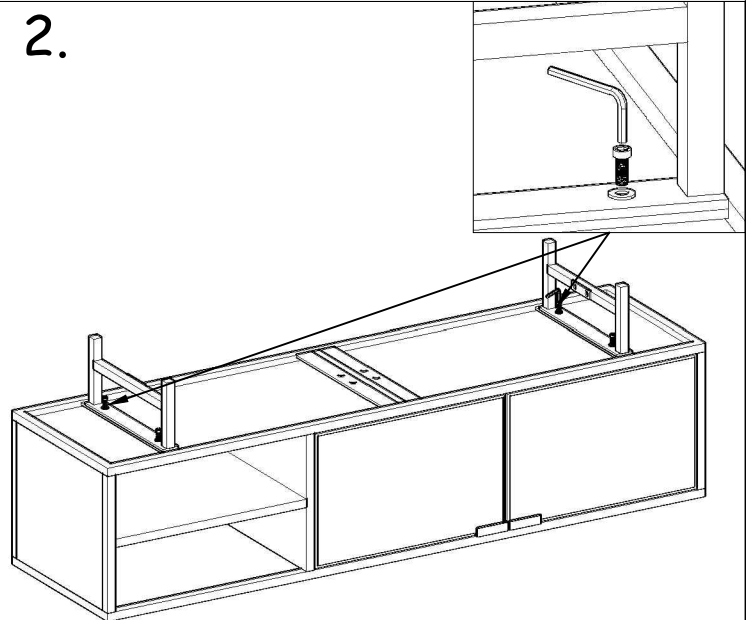

3.

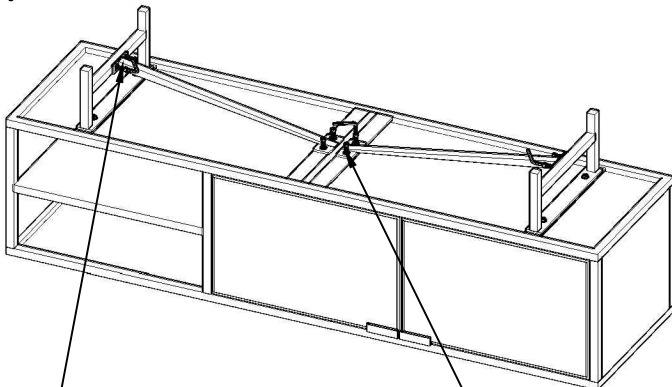

4.

