

Ax1

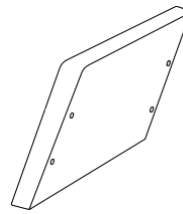

Bx1

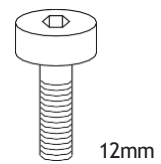

Ex12



Fx12

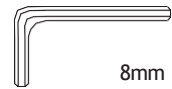

Gx1

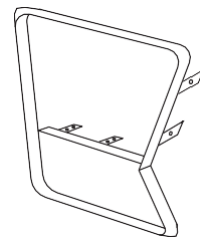

Cx1

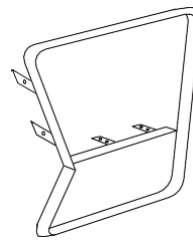

Dx1



20 min.

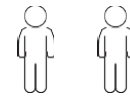

x2

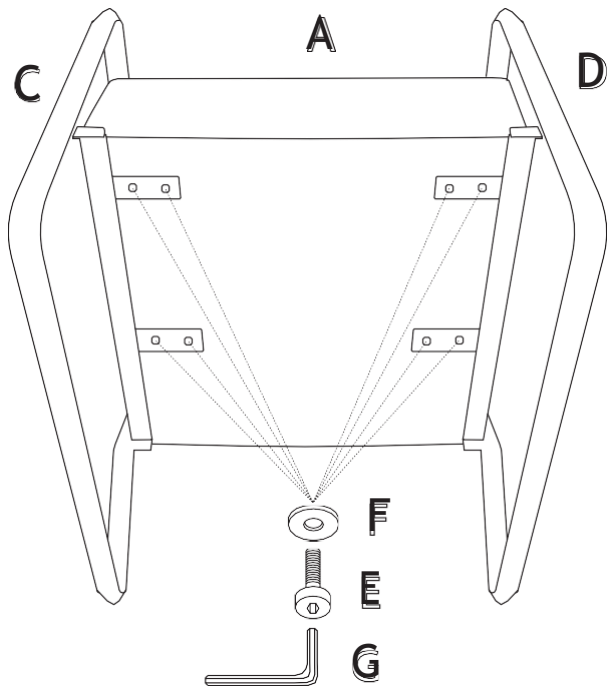

Étape 1 : Assemblez le siège avec les accoudoirs, puis serrez les vis, de sorte que nous puissions facilement remonter.

Step 1 : Assemble seat with arm rests, then tighten the screws, so that we can easily assemble back.

Étape 2 : Maintenant, alignez-vous sur les trous donnés et serrez les vis.

Step 2 : Now align back to the given holes and tighten the screws.

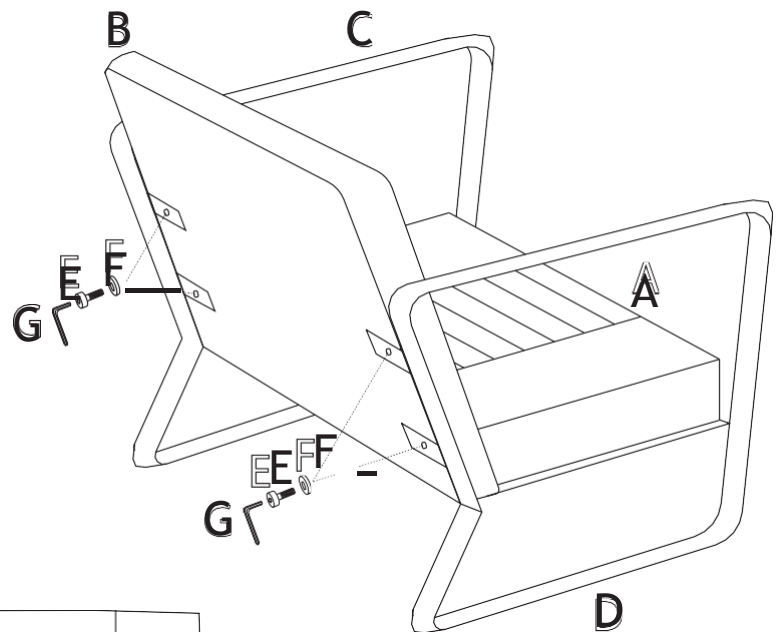

Remarque : Serrez d'abord partiellement les vis et lorsque l'ensemble du produit est assemblé, serrez complètement les vis.

Note : At first partially tighten the screws and when whole product is assembled then fully tighten the screws.

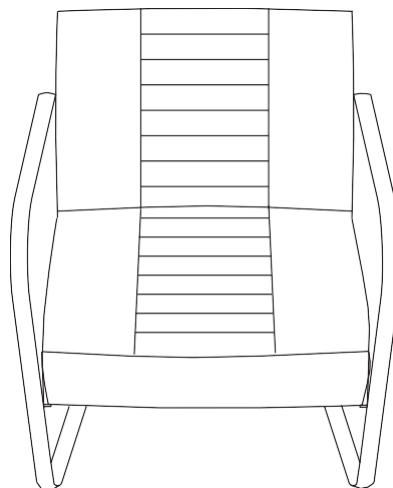

Étape 3 : Le produit est prêt à l'emploi.

Step 3 : Product is ready to use.

